



SmartLink™ SL-2-DC Operations Manual

Version 0.B

Table of Contents

Revision History	1
SmartLink SL-2-DC Introduction	2
Setup Guide	3
Installation & Activation	3
Features and Functions	4
Cellular Connection	6
Interfaces	7
Block Diagram	8
Dimensions	9
Wiring Diagram	10
Digital System Example	10
Solar System Example	12
Specification Summary	13

Revision History

Version	Author	Summary
0.0	C. Weiland	Initial Release

SmartLink SL-2-DC Introduction

SmartLink SL-2-DC controllers remotely manage devices through a secure, cloud-based management system. The SL-2-DC operates from 8 – 30 volts @ 3A per output and has two independently controlled inputs and outputs. This allows a single SL-2-DC controller to remotely monitor, schedule and reboot two separate devices operating at different voltages.

The versatile controller is useful in a variety of applications and industries including:

- Digital Advertising & Signage
- IT & Networking
- Lighting Systems
- Solar Systems

Every SmartLink SL-2-DC controller can be accessed from a desktop or mobile device, enabling operations teams to manage issues before customers see them and resolve problems in seconds without making a site visit.



Reboot Devices from Anywhere



Schedule up to 2 Devices per Controller



Receive Alerts in Real-time



24/7 Proof of Performance



Reduce Site Visits & Carbon Footprint



Management & Performance Reports

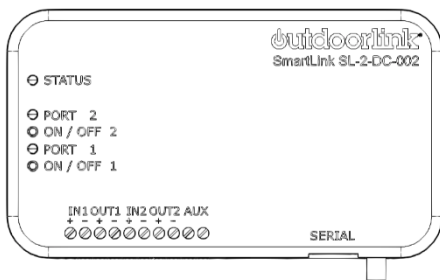

OutdoorLink offers 24/7 technical support via phone or email from its Huntsville-based support team to ensure issues are resolved as soon as possible. Please call (256) 885-9768 or email support@outdoorlinkinc.com to reach a support representative.

Setup Guide

Installation & Activation

Please read the following instructions prior to installation.

1. Please refer to example wiring diagrams in this manual and contact customer support if there are any installation questions. Outdoorlink, Inc. recommends that all applicable electrical codes be observed while installing and troubleshooting the units. Please note that electrical codes vary by area. Consult local electrical codes prior to installation.
2. **Once the SL-2-DC unit is installed, contact Outdoorlink customer support at (256) 885-9768 to activate your unit and to ensure the system is operating properly. The device will not operate until this step is complete.**

Please have the following details known or readily available:

- a. Location the SL-2-DC Unit is installed
 - b. GPS Coordinates (if applicable)
 - c. Devices connected to the SL-2-DC unit
 - d. Desired scheduling (device on/off & day of week)
 - e. ICCID – Numeric identifier is labeled on the enclosure. Ex. 89014103271407802097
3. If not yet completed, customer support will create a user web account to access the Portal. Portal training will be provided by an Outdoorlink representative when requested. A Portal user manual is also available for a complete review of the system.
 4. Once the SL-2-DC unit is powered up and customer support has activated the device, please log in to the Portal at <https://portal.outdoorlinkinc.com/login> using the provided credentials to begin remotely managing devices.

Features and Functions

OutdoorLink’s controllers remotely monitor, schedule, and reboot digital inventory through a cloud-based management portal. As a third-party fail-safe, users are alerted in real-time and the SmartLink can remotely reboot the device to restore proper function.

The SL-2-DC enables up to two devices to operate on different run-times with individual day-of-week scheduling capabilities. And with an open API, the SmartLink Management System can integrate with other Content Management Systems and CAD-AVL platforms.

SL-2-DC Specifications

Device Management	Manages up to 2 DC powered devices: security & illumination lighting, digital displays, cameras and more
Runtime Settings	Automatic, GPS based sunrise/sunset times and/or manual time scheduling with integrated real-time clock
Enclosure	Polycarbonate, 6 in. x 3 in. x 1 in.
Input Power	8-30Vdc
Output Power	8-30Vdc @ 3A per port
Connectivity	Cellular LTE CAT M1 cellular connection with internal SIM and integrated or external antenna options
Operating Temp.	0°C to 65°C
Environmental	0-95% humidity, non-condensing, RoHS
Wiring Connections	Terminal block (18 AWG)
System Reporting	Power Readings, Proof of Performance, Alarm History, Maintenance Log, Temperature Probe
Alarm Notifications	Loss of Power, Low Voltage, High Voltage, Power Restore, No current

SL-2-DC Advanced Features

Variable Dimming allows a user to remotely set and schedule the intensity of lighting. A user can set the dimming percentage along with the scheduled on – off period. This is especially important for solar applications where reduced light intensity equates to reduced power consumption.

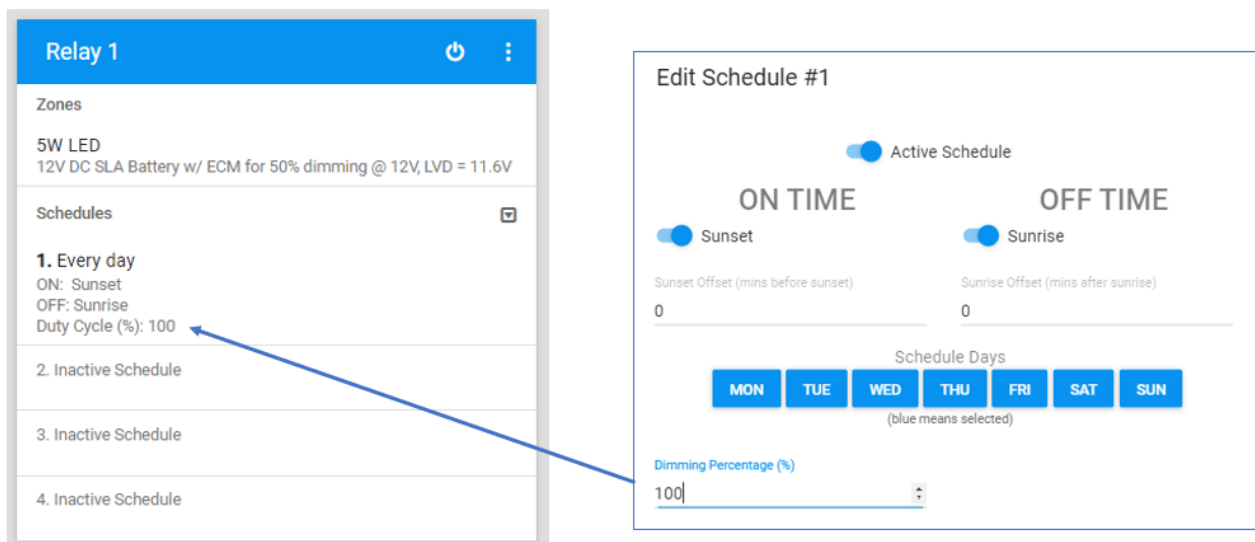

Voltage Threshold Actions (VTA) monitors the input voltage and as a function of its level invokes certain actions. There are two thresholds provided, each with six selectable actions that can be assigned and executed once the threshold is met. The thresholds are setup as high and low levels. This allows an action to be taken when the input voltage exceeds the high level and for an action to be taken when the input voltage is less than the low level. Combining the associated actions and levels allows for robust control of the outputs.

The input voltage threshold levels are common between the two outputs. However, the output actions are independent of one another. For example, once a threshold has been met output 1's action may be to remain idle and do nothing while output 2's action may be to open or turn off.

The six action selections for each of the voltage thresholds are outlined the table below. Only one action may be assigned to a relay threshold at a time. VTA is configurable by users with administrative access.

Action	Description
None/Idle	No action is taken.
Follow Schedules	Relay follows the assigned schedules. If a schedule on time is valid the relay will close.
Open Relay	Relay is opened and remains open until the next schedule on time. This functionality is equivalent to a manual off from the web portal.
Open Relay, Ignore Schedules	Relay is opened and its associated schedules are ignored. The relay schedules will continue to be ignored until another relay action is taken or a manual relay on or off is issued from the web portal.
Close Relay	Relay is closed and remains closed until the next schedule off time following a scheduled-on time. This functionality is equivalent to a manual on from the web portal.
Close Relay, Ignore Schedules	Relay is closed and its associated schedules are ignored. The relay schedules will continue to be ignored until another relay action is taken or a manual relay on or off is issued from the web portal.

Cellular Connection

The SL-2-DC includes an integrated cellular modem to enable communication between the device and OutdoorLink’s servers. The SL-2-DC uses LTE CATM1 cellular technology which is designed for IoT devices. The SL-2-DC has two antenna modes – internal and external – and is configured to internal mode when shipped.

It is critical that the SL-2-DC is configured for the proper antenna mode. A user may change antenna mode by pressing the “ON/OFF 2” or “ON/OFF 1” push buttons for 5 seconds. The Status LED provides visual confirmation of what antenna mode the SL-2-DC is set to.

Installation Tips:

- Avoid placing the SL-2-DC in enclosed spaces unless necessary. An external antenna is recommended when the device must be placed in an enclosed area such as a hardware cabinet.
- When mounting external antennas, orientation and plane are important factors to consider. Verify with OutdoorLink on the ideal mounting position.
- Place the SL-2-DC with as much free space as possible from other electronic devices.

Status LED

- Slow Blink: One blink per second indicates that the device is searching for the cellular network.
- Rapid Blink: Multiple blinks per second confirms the device is connected to the cellular network **AND** configured for **internal** antenna mode.
- Rapid Blink with One Second Pause: Rapid blink for five seconds followed by a one second pause confirms that the device is connected to the cellular network **AND** configured for **external** antenna mode.

Port 1,2 LED

- A solid LED light indicates Port 1,2 is powered with a load connected.
- A rapid blink LED light indicates Port 1,2 is powered without a load connected.
- No LED light indicates Port 1,2 is not powered.

On/Off 1,2

- Push button to toggle Port 1,2 to ON or OFF position.

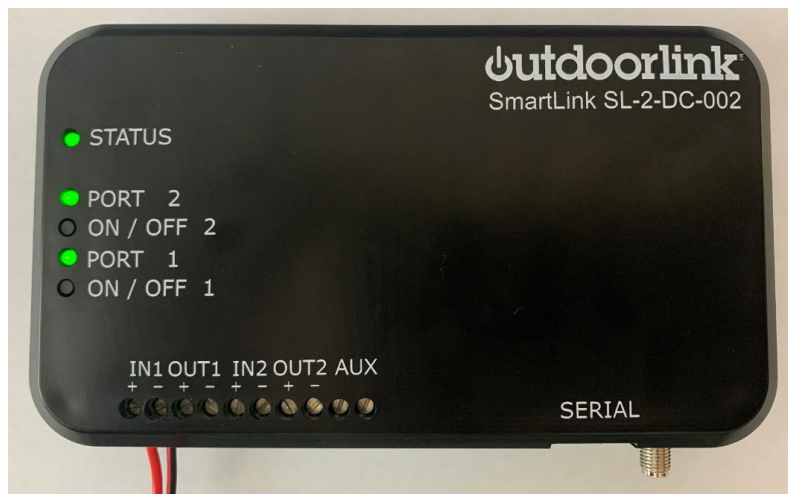

Interfaces



Interface List	
1	Terminal Block IN1 (+)
2	Terminal Block IN1 (-)
3	Terminal Block OUT1 (+)
4	Terminal Block OUT1 (-)
5	Terminal Block IN2 (+)
6	Terminal Block IN2 (-)
7	Terminal Block OUT2 (+)
8	Terminal Block OUT2 (-)
9	Terminal Block Temp/AUX
10	Terminal Block Temp/AUX
11	USB 2.0 Micro-B Female
12	RJ45 to Serial -002 version Dual RJ45 to Serial + Network -001 version
13	Antenna Port Internal Antenna – Standard External Antenna - Optional

Block Diagram

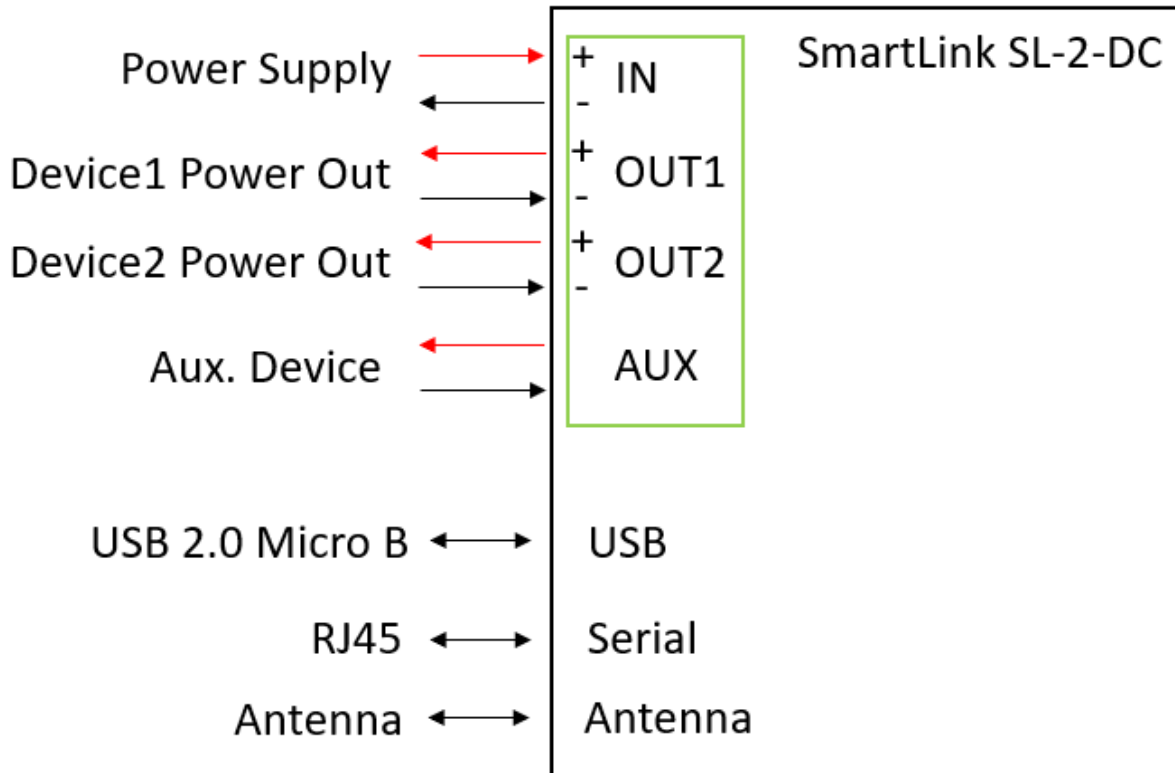

Note – An 11mm extended tip Micro B Male is recommended for accessing the micro USB port.
 Amazon ASIN - B07R1Z9HYP

Dimensions

SL-2-DC Size & Weight Details	
Material	PC/ABS UL94
Color	Black
Weight	5.8 oz.
Length	5.82 in.
Width	3.60 in.
Height	0.95 in.

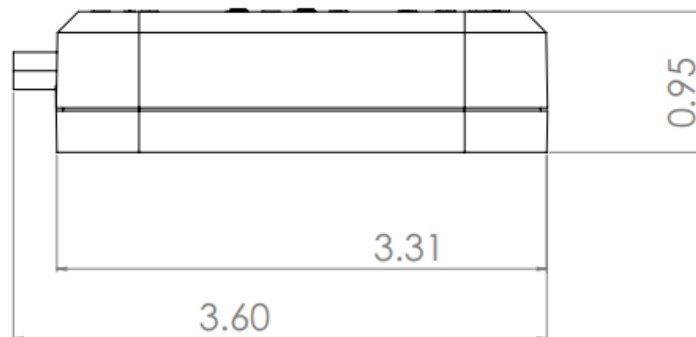
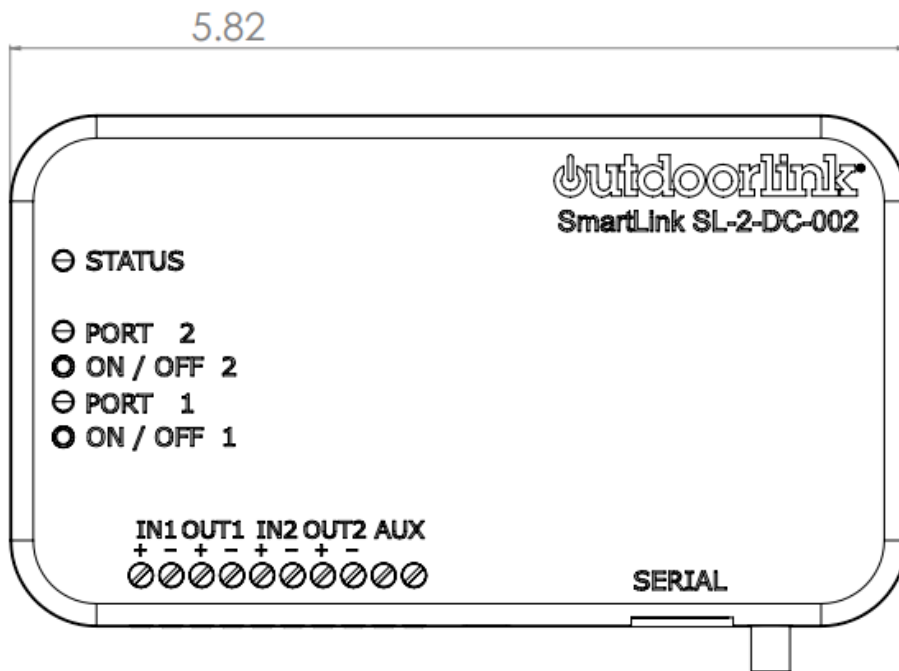

Wiring Diagram

Digital System Example

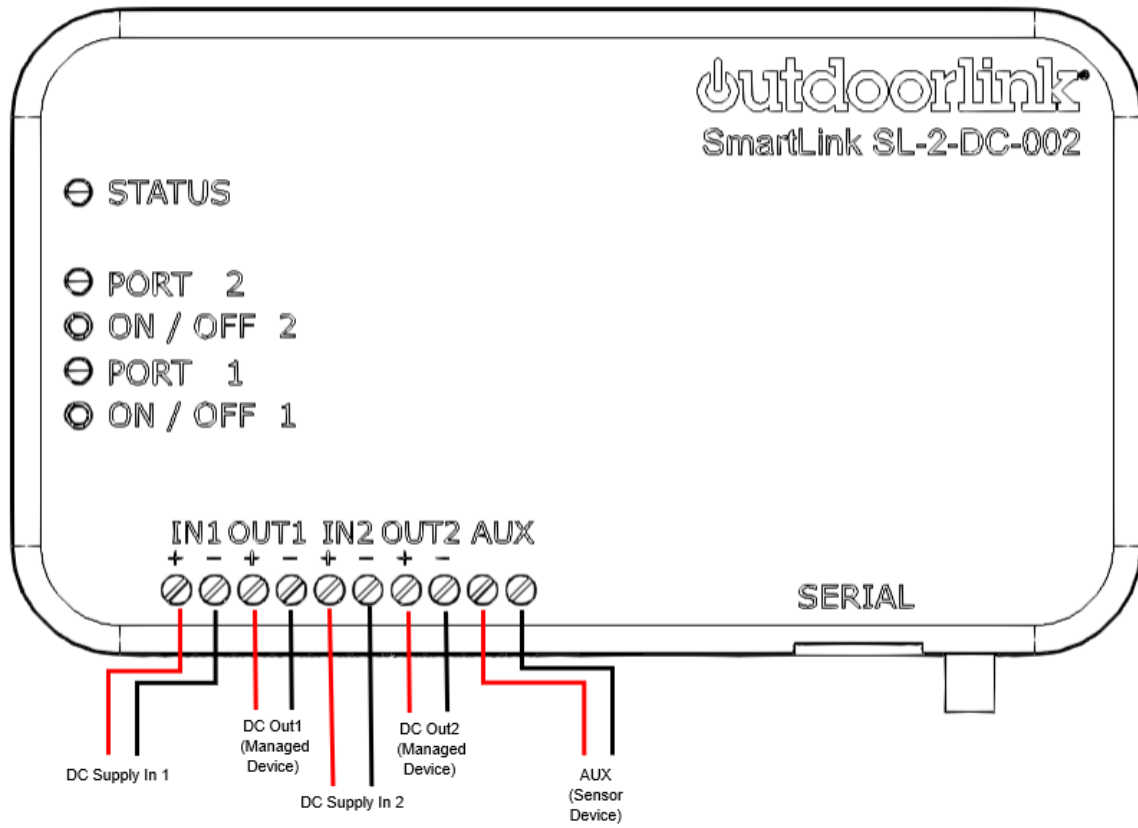

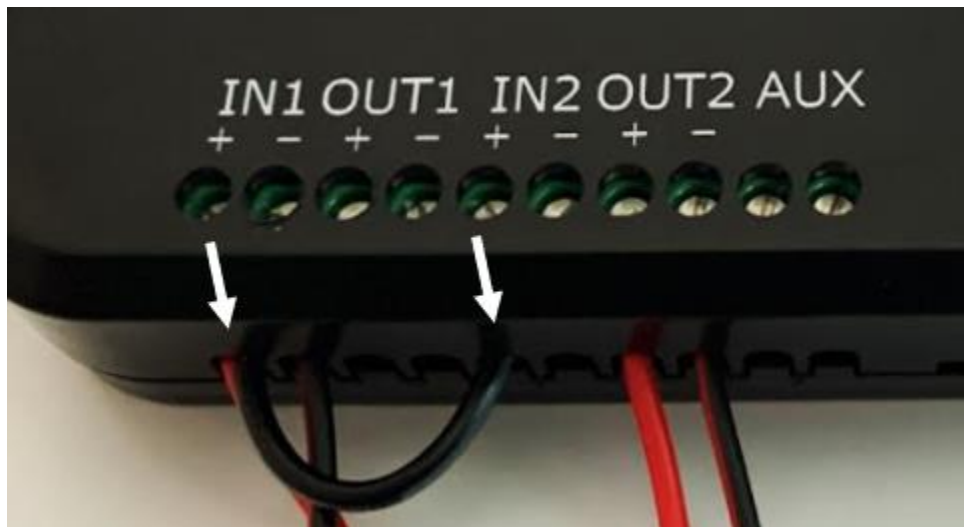
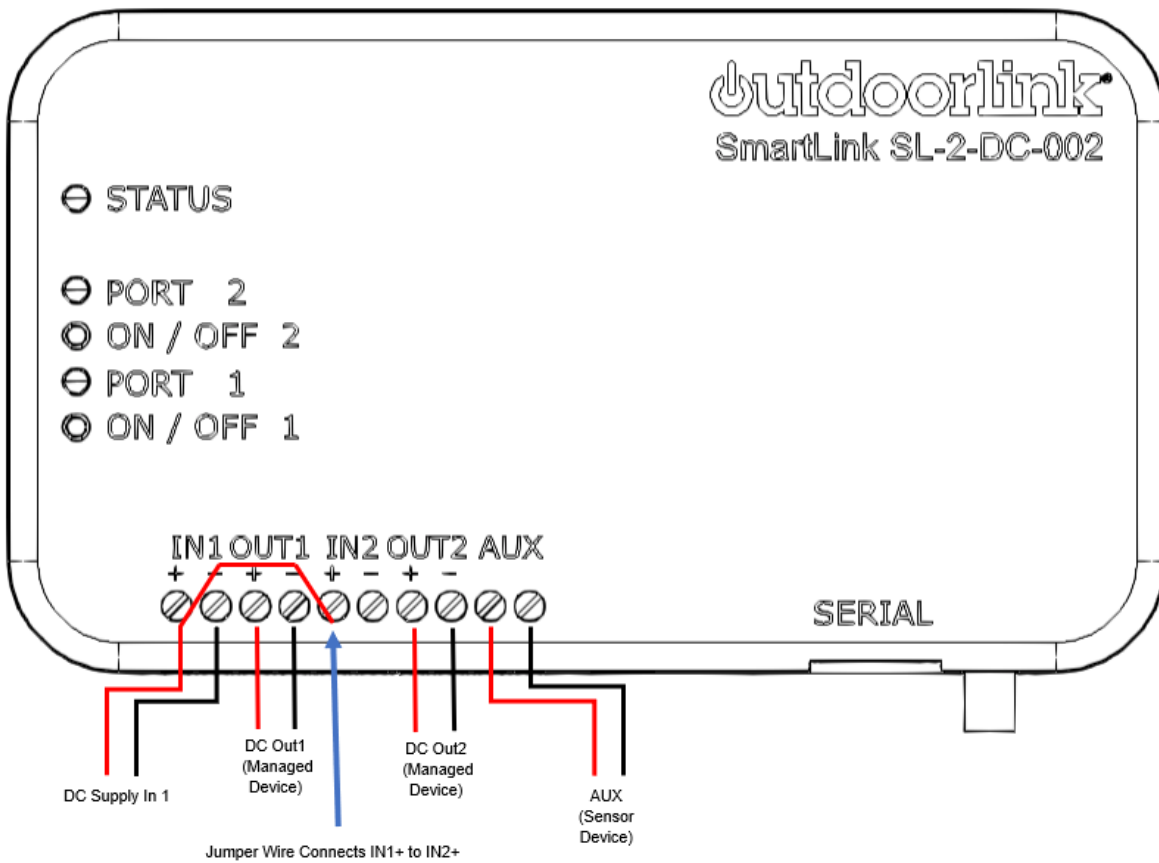

Solar System Example

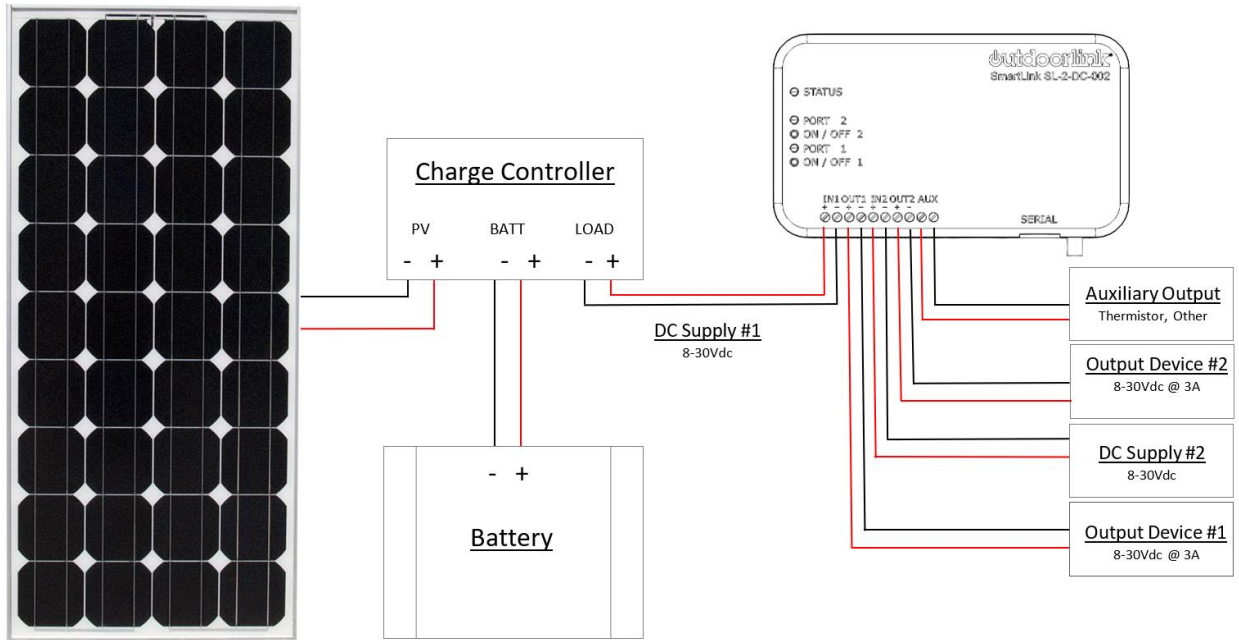

Specification Summary

1. Measurement Capability
 - a. Input Voltage/Battery Voltage (supply)
 - b. Output Current (per port)
 - c. Temperature (thermistor)
2. Multiple Device Management
 - a. Ability to remotely manage up to two devices per controller.
 - b. Ability to remotely dim lighting through scheduling or on-demand command.
 - c. Ability to automatically change relay position based on input voltage levels.
3. Rebooting
 - a. Reboot devices individually from any desktop or mobile device.
 - b. Verification after a device has been rebooted.
4. Connectivity
 - a. LTE CAT M1 cellular connection with internal SIM and integrated antenna with external antenna option.
 - b. Utilizes an independent cellular connection. Does not require dependence on a cellular connection of another device's board.
5. Scheduling
 - a. Run-time settings defined automatically with GPS based sunrise/sunset times and/or manual time scheduling.
 - b. Internal real-time clock provides automatic and accurate daylight savings adjustments.
 - c. Schedule up to two devices independently.
 - d. Day-of-week scheduling capabilities per output.
 - e. Up to four schedules per output.
6. System Notifications
 - a. Users notified in real-time via email of system alarms due to loss of power, no power and power restore.
7. Power Management
 - a. Input power: 8 to 30Vdc
 - b. Output power: 8 to 30Vdc @ 3A per port. Output voltage matches input voltage.
8. Environmental
 - a. 0-95% humidity, non-condensing, RoHS.
 - b. Operating/Storage Temperature: 0°C to 65°C
9. Installation
 - a. 18 AWG terminal block connections.
 - b. 24/7 on-call technical support.
10. Software
 - a. Cloud based access from any desktop or mobile-friendly browser compatibility.
 - b. Hosted by a secure cloud-based Amazon Web Service (AWS).
 - c. Open API for integration into third-party content management or CAD-AVL systems.
 - d. Provides reports and charting of Power Readings, Proof of Performance, Command Logs, Maintenance Logs and Alarm History.